

PONARC

INSTALLATION GUIDE

Luxa Sereno

700

Bioclimatic Pergola

A bioclimatic louvre roof that turns your terrace  
into a four-season room.

A LUXASHADE PRODUCT

 LUXASHADE

EN

# 8 steps to a finished bioclimatic pergola.

TOTAL TIME

**3h 22m**

summed across all 10 steps

CREW

**2 installers**

recommended throughout

DIFFICULTY



moderate - power tools required

EDITION

**2026.1**

January 2026 · EN

<b>01</b>	<b>Place the foot plates</b> First action on the slab — anchor plates set the system footprint.	<b>FOUNDATION</b>	45-60 min
<b>02</b>	<b>Lift the four columns</b> Lift the four columns onto the anchor studs — two installers per column.	<b>FOUNDATION</b>	20-30 min
<b>03</b>	<b>Set the front carrier beam</b> Front carrier beam goes on first — the spine of the frame.	<b>FRAME</b>	15-20 min
<b>04</b>	<b>Set the back carrier beam</b> Back carrier beam closes the front-to-rear span — keep beams parallel.	<b>FRAME</b>	15-20 min
<b>05</b>	<b>Add the left short beam</b> Left short beam ties the long beams — frame becomes self-supporting.	<b>FRAME</b>	10-15 min
<b>06</b>	<b>Add the right short beam</b> Right short beam closes the rectangle — measure both diagonals now.	<b>FRAME</b>	10-15 min
<b>07</b>	<b>Install the first row of lamels</b> First row of lamels enters the rail — verify free rotation by hand.	<b>LAMELS</b>	30-45 min
<b>08</b>	<b>Complete the lamel array</b> Complete the lamel array — final check before motorizing the system.	<b>LAMELS</b>	25-35 min

FOUNDATION · STEP D1

# 01 Place the foot plates

First action on the slab — anchor plates set the system footprint.

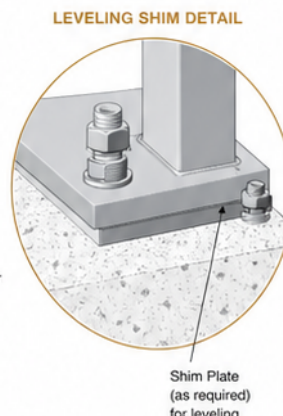
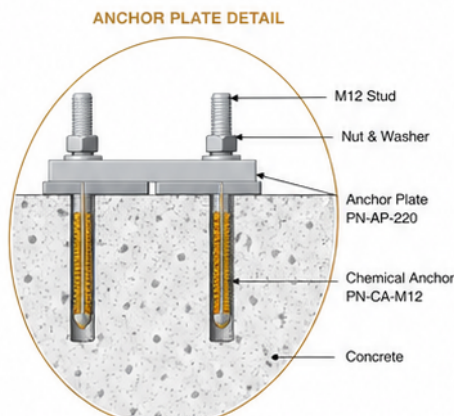
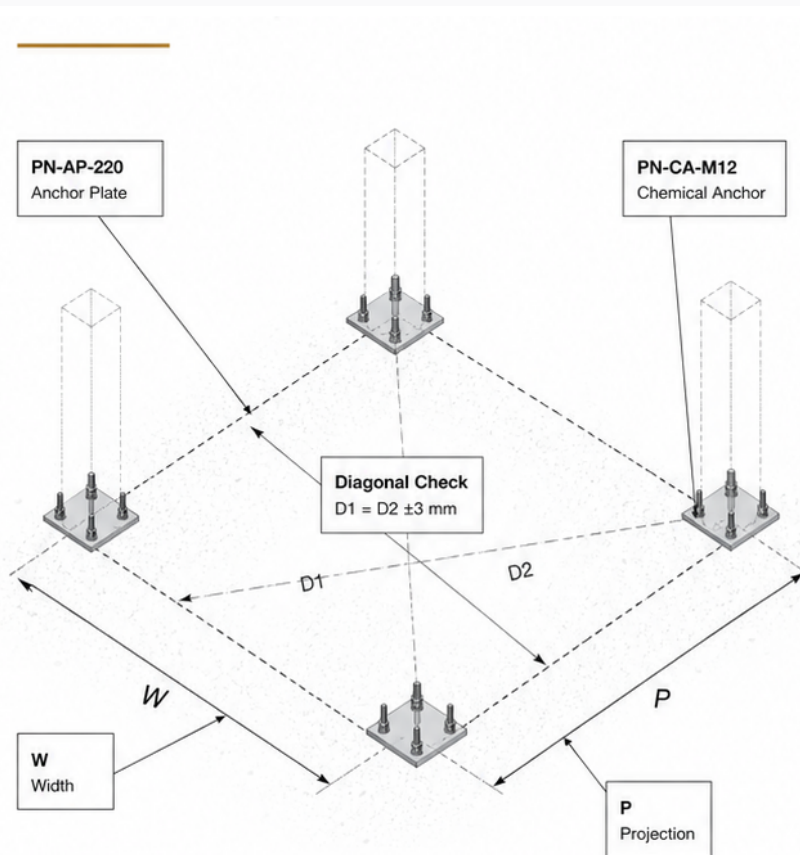

# 01 Place the foot plates

First action on the slab — anchor plates set the system footprint.

- 01
- 02
- 03
- 04
- 05
- 06
- 07
- 08



## SUB-STEPS

- 1 Mark the four corner positions according to the site survey.
- 2 Verify the W x P footprint and confirm both diagonals match within tolerance.
- 3 Drill anchor holes and inject chemical anchor resin.
- 4 Insert M12 studs and allow the specified cure time.
- 5 Set each anchor plate level with shims and tighten the nuts.
- 6 Confirm all four plates are coplanar before proceeding.



## SPECIFICATIONS

- Anchor plate: 220 x 220 x 12 mm anodised aluminium
- Anchor type: M12 chemical anchor
- Hole: Ø14 mm x 90 mm depth
- Torque: 60 Nm
- Tolerance: diagonals ±3 mm, coplanar ±2 mm



## TIP

Measure both diagonals before drilling to prevent column misalignment.



## WATCH OUT

Do not install plates near slab edges or expansion joints.



## TOOLS

Tape measure, chalk line, hammer drill, torque wrench, spirit level



## TIME

45-60 min

NEXT

## D2

Lift the four columns



FOUNDATION · STEP D2

# 02 Lift the four columns

Lift the four columns onto the anchor studs — two installers per column.

01

02

03

04

05

06

07

08

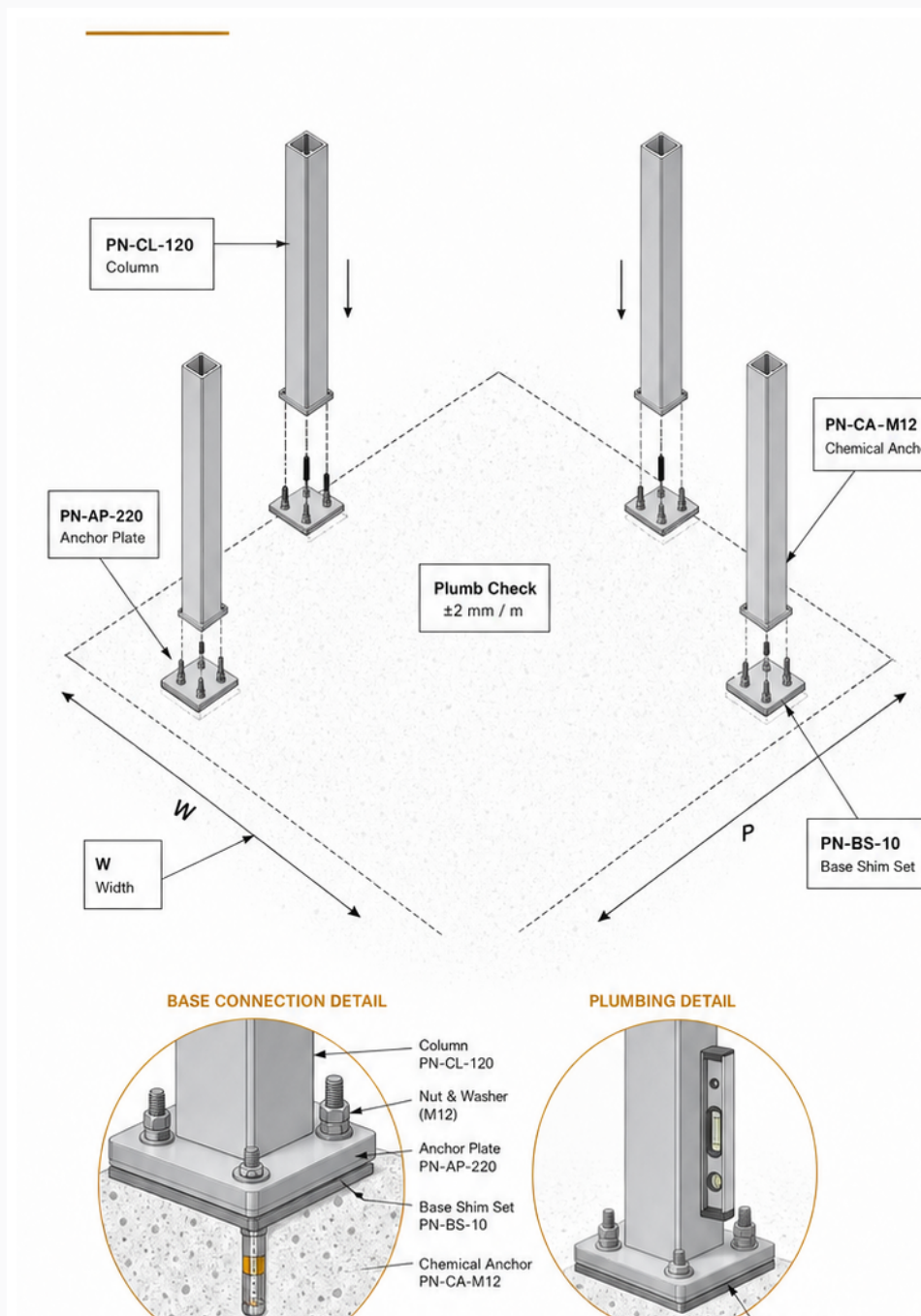

PONARC

# 02 Lift the four columns

Lift the four columns onto the anchor studs — two installers per column.



### SUB-STEPS

- 1 Lift each column and lower it onto the corresponding anchor plate.
- 2 Align the base holes with the M12 studs.
- 3 Insert washers and nuts loosely at all four corners.
- 4 Check column plumb in both directions.
- 5 Add shims where required and tighten progressively.
- 6 Confirm all columns are aligned before continuing.



### SPECIFICATIONS

- Column profile: PN-CL-120
- Section: 120 x 120 mm
- Fastener: M12 washer + nut set
- Plumb tolerance:  $\pm 2$  mm / m
- Applicable to: 4 columns



### TIP

Use temporary braces or a second installer to hold the column plumb while the nuts are engaged.



### WATCH OUT

Do not fully torque base nuts until the beam frame is assembled.



### TOOLS

Soft sling, spirit level, torque wrench, shim plates



### TIME

20-30 min

NEXT

## D3

Set the front carrier beam



# 03

## Set the front carrier beam

Front carrier beam goes on first — the spine of the frame.

01

02

03

04

05

06

07

08

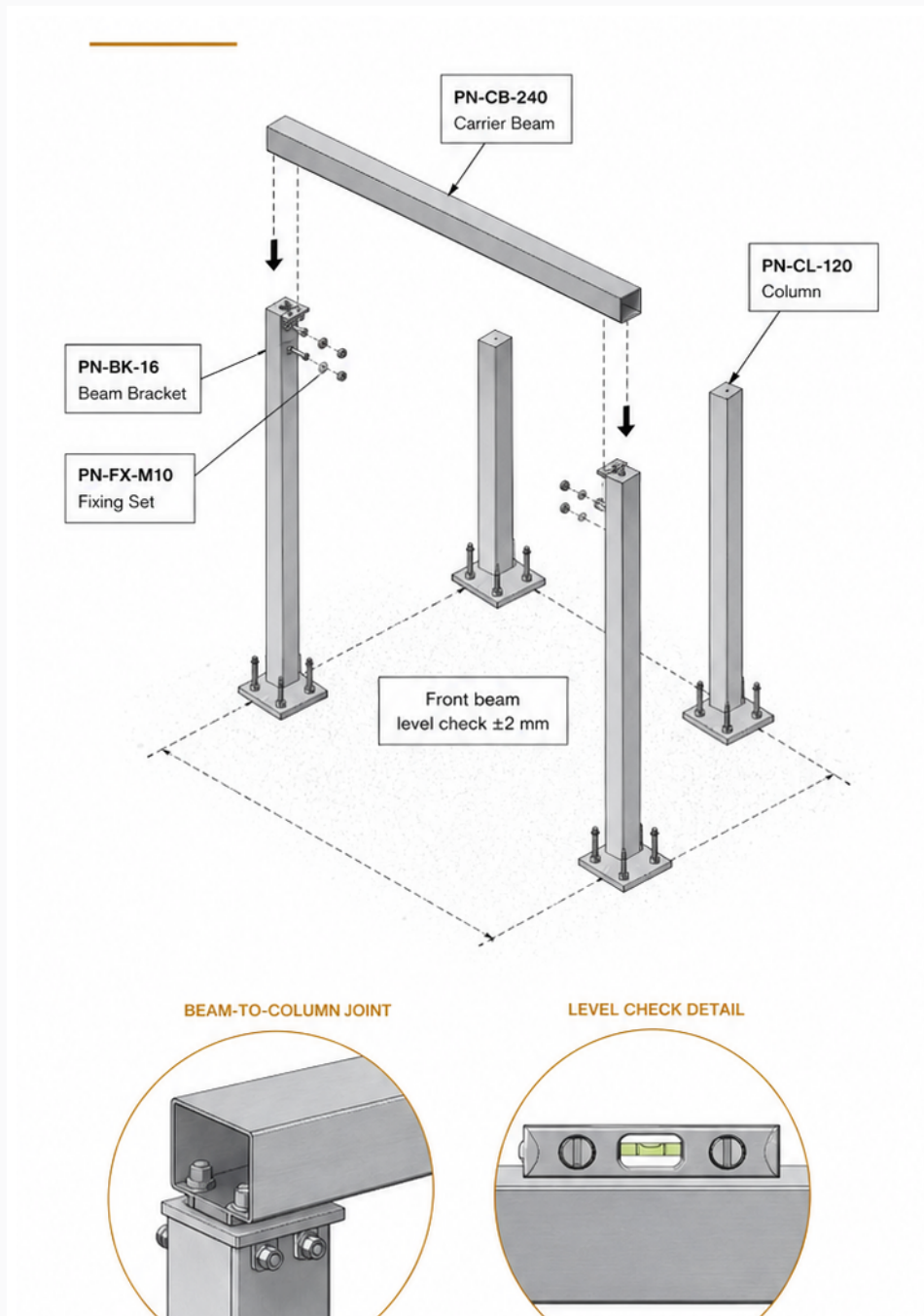

# 03

## Set the front carrier beam

Front carrier beam goes on first — the spine of the frame.

- 01
- 02
- 03
- 04
- 05
- 06
- 07
- 08



### SUB-STEPS

- 1 Lift the front carrier beam with two installers.
- 2 Seat the beam onto the front column heads.
- 3 Align fixing holes and insert the M10 fixing set.
- 4 Tighten lightly on both ends.
- 5 Verify level across the full width.
- 6 Confirm equal overhang and alignment before tightening.



### SPECIFICATIONS

- Beam profile: PN-CB-240
- Fastener set: M10 stainless fixing set
- Level tolerance:  $\pm 2$  mm
- Install team: 2 installers
- Tightening stage: preliminary



### TIP

Start one side first, then support and align the opposite side before inserting bolts.



### WATCH OUT

Do not force the beam into misaligned brackets.



### TOOLS

Lift support, hex keys, spirit level, torque wrench



### TIME

15-20 min

NEXT

## D4

Set the back carrier beam



# 04

## Set the back carrier beam

Back carrier beam closes the front-to-rear span — keep beams parallel.

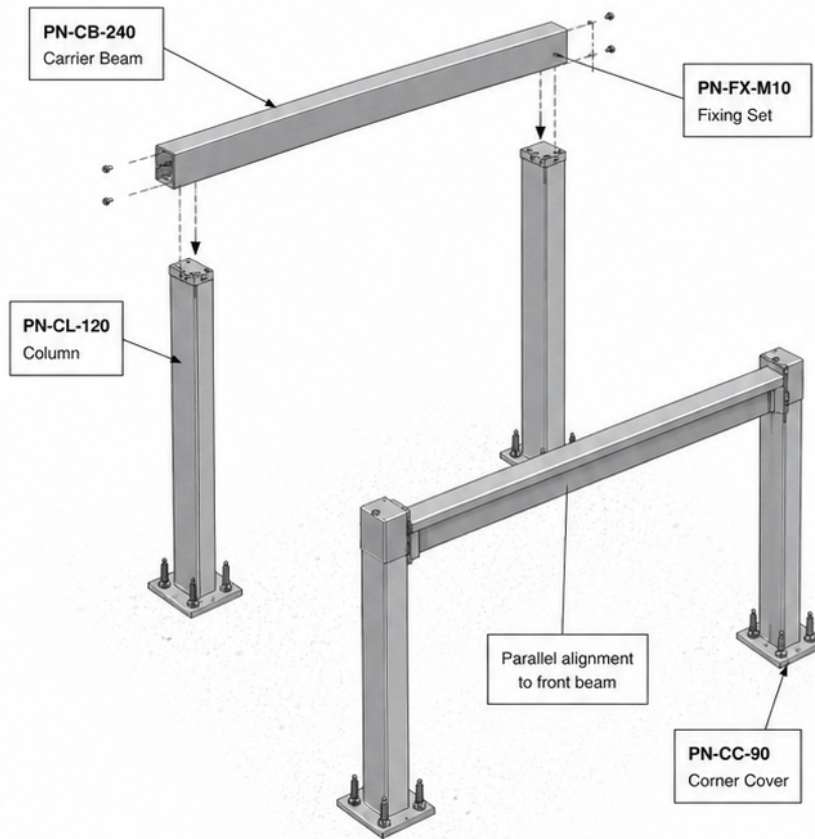

REAR JOINT DETAIL

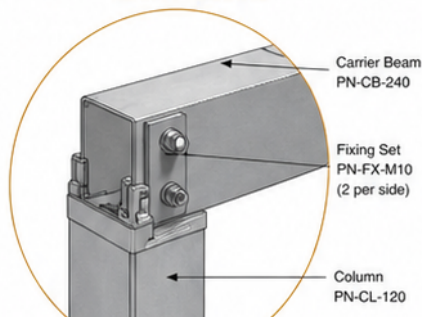

PARALLEL CHECK DETAIL

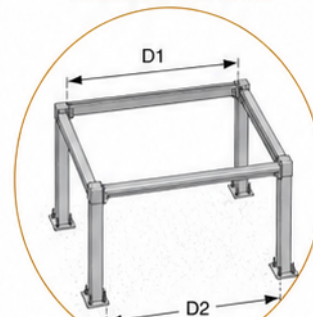

# 04

## Set the back carrier beam

Back carrier beam closes the front-to-rear span — keep beams parallel.



### SUB-STEPS

- 1 Lift the rear carrier beam into position.
- 2 Seat the beam on both rear column heads.
- 3 Insert fixing set loosely on both ends.
- 4 Measure spacing between front and rear beams.
- 5 Confirm beams are parallel and level.
- 6 Tighten beam connections progressively.



### SPECIFICATIONS

- Beam profile: PN-CB-240
- Parallel tolerance:  $\pm 2$  mm
- Fasteners: M10 stainless fixing set
- Corner trim: PN-CC-90
- Install team: 2 installers

01  
02  
03  
**04**  
05  
06  
07  
08



### TIP

Measure side distances between front and rear beams to ensure the frame is not twisted.



### WATCH OUT

Unequal spacing will cause lamel rail misalignment later.



### TOOLS

Tape measure, level, hex keys, torque wrench



### TIME

15-20 min

NEXT

## D5

Add the left short beam



# 05

## Add the left short beam

Left short beam ties the long beams — frame becomes self-supporting.

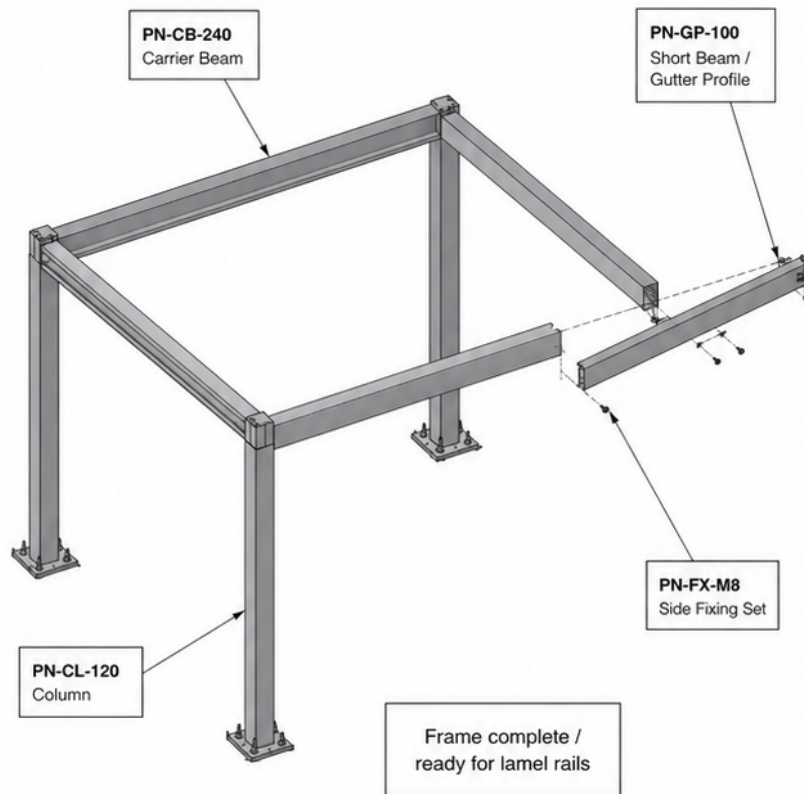

RIGHT CORNER DETAIL

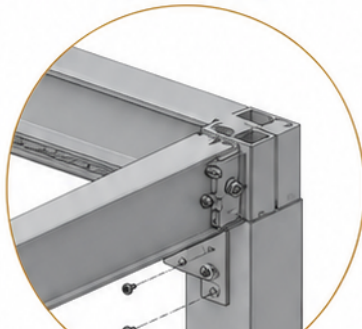

DIAGONAL CHECK DETAIL

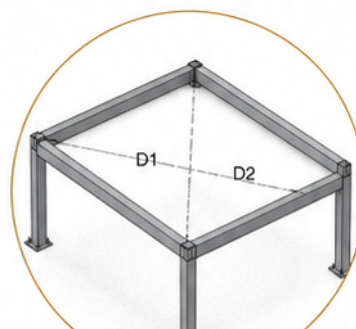

# 05

## Add the left short beam

Left short beam ties the long beams — frame becomes self-supporting.



### SUB-STEPS

- 1 Position the left short beam between front and rear beams.
- 2 Align corner interfaces on both ends.
- 3 Insert side fixing set and tighten lightly.
- 4 Check the side is flush along the full depth.
- 5 Verify the frame remains square.
- 6 Tighten after confirming alignment.



### SPECIFICATIONS

- Short beam / gutter profile: PN-GP-100
- Side fasteners: M8 fixing set
- Flushness tolerance:  $\pm 2$  mm
- Frame geometry: square footprint
- Install team: 2 installers

- 01
- 02
- 03
- 04
- 05**
- 06
- 07
- 08



### TIP

Clamp the profile temporarily before installing the second fixing point.



### WATCH OUT

If the profile is not fully seated, the opposite side may not align.



### TOOLS

Clamp, hex keys, square, torque wrench



### TIME

10-15 min

NEXT

## D6

Add the right short beam



# 06

## Add the right short beam

Right short beam closes the rectangle — measure both diagonals now.

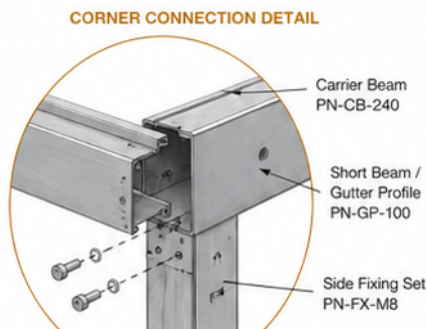
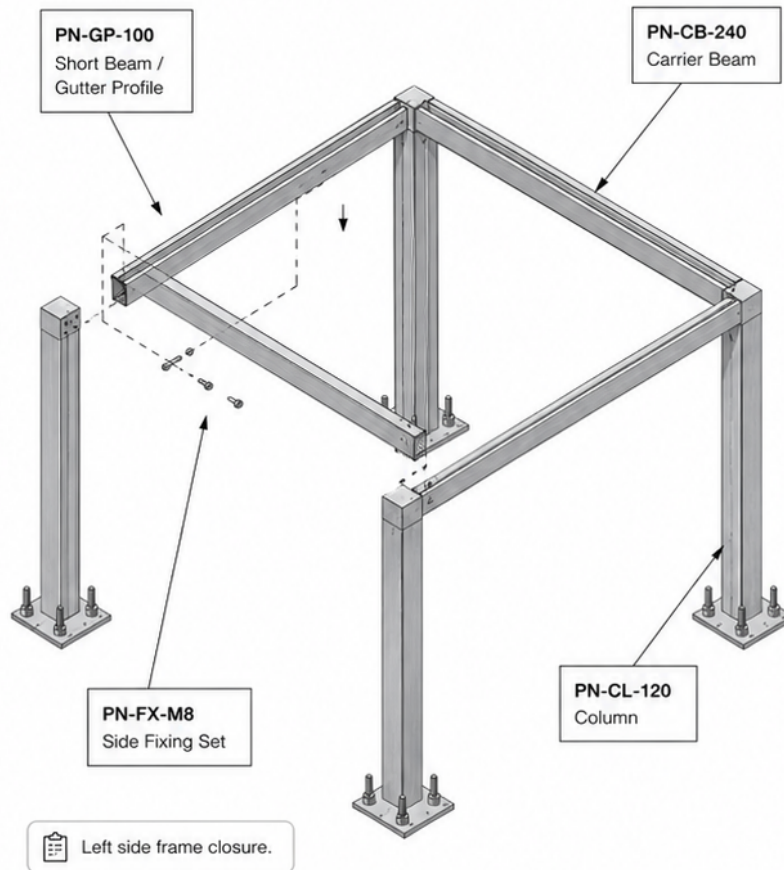

# 06

## Add the right short beam

Right short beam closes the rectangle — measure both diagonals now.



### SUB-STEPS

- 1 Position the right short beam into the open side of the frame.
- 2 Align both end joints with the carrier beams.
- 3 Insert fixing set and clamp lightly.
- 4 Measure two diagonals to confirm squareness.
- 5 Tighten the right side fasteners.
- 6 Confirm the frame is ready for lamel rails.



### SPECIFICATIONS

- Short beam / gutter profile: PN-GP-100
- Diagonal tolerance:  $\pm 3$  mm
- Side fasteners: M8 fixing set
- Frame status: fully closed rectangle
- Install team: 2 installers

- 01
- 02
- 03
- 04
- 05
- 06**
- 07
- 08



### TIP

Measure both diagonals after the right side closes the frame.



### WATCH OUT

A twisted frame will bind the lamels during rotation.



### TOOLS

Tape measure, square, clamp, torque wrench



### TIME

10-15 min

NEXT

## D7

Install the first row of lamels



# 07

## Install the first row of lamels

First row of lamels enters the rail — verify free rotation by hand.

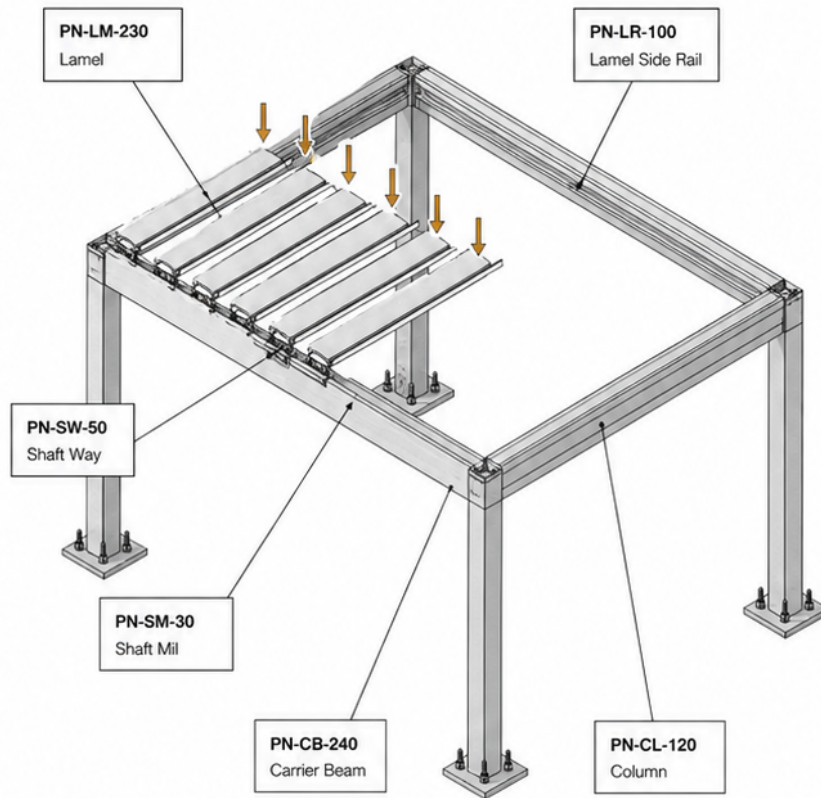

SHAFT WAY DETAIL

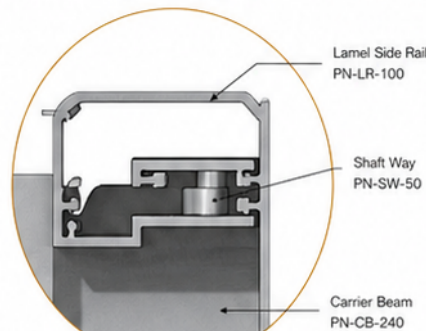

LAMEL CONNECTION DETAIL

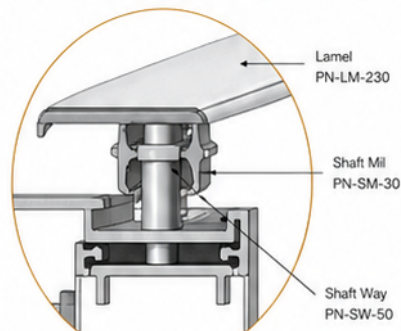

# 07

## Install the first row of lamels

First row of lamels enters the rail — verify free rotation by hand.



### SUB-STEPS

- 1 Insert the first lamel into the side rail guides.
- 2 Align both pivot ends with the shaft-way connection points.
- 3 Fasten the shaft-mil linkage and verify free rotation.
- 4 Check spacing and parallel alignment before tightening.
- 5 Repeat for the first row.



### SPECIFICATIONS

- Lamel profile: PN-LM-230
- Rotation range: up to 115°
- Recommended team: 2 installers
- Estimated time: 30-45 min
- Alignment tolerance: ±2 mm



### TIP

Start from the reference edge and keep each lamel parallel to the previous one.



### WATCH OUT

Do not force a lamel into the guide rail.



### TOOLS

Hex keys, torque wrench, soft mallet, step ladder



### TIME

30-45 min

NEXT

## D8

Complete the lamel array



# 08

## Complete the lamel array

Complete the lamel array — final check before motorizing the system.

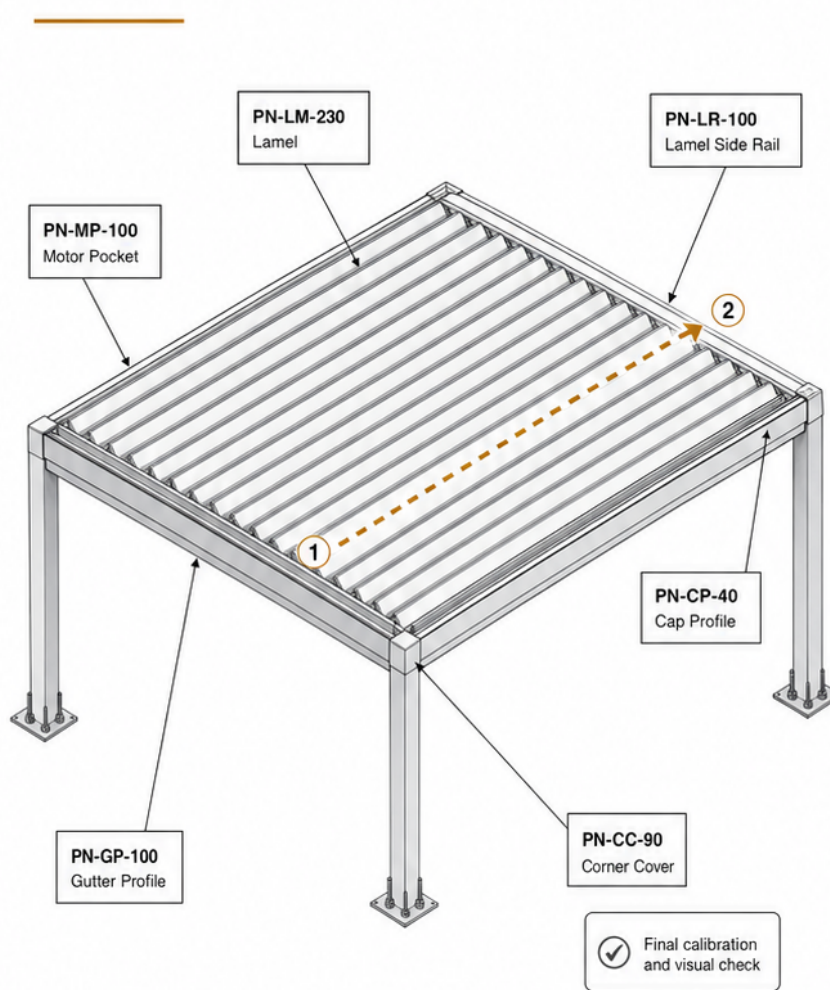

END CAP DETAIL

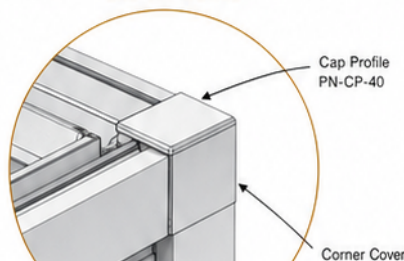

FINAL LAMEL DETAIL

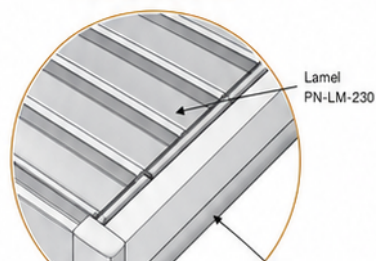

# 08

## Complete the lamel array

Complete the lamel array — final check before motorizing the system.



### SUB-STEPS

- 1 Continue installing remaining lamels across the frame.
- 2 Verify even spacing and smooth rotation.
- 3 Install cap profile and corner cover components.
- 4 Connect motor pocket and linkage if required.
- 5 Run a full open/close cycle for calibration.
- 6 Carry out final visual inspection.



### SPECIFICATIONS

- Lamel profile: PN-LM-230
- Maximum rotation: 115°
- Cap profile: PN-CP-40
- Corner cover: PN-CC-90
- Final alignment: visually uniform



### TIP

After the final lamel is installed, perform one slow test cycle before handover.



### WATCH OUT

Uneven spacing or resistance indicates alignment issues.



### TOOLS

Hex keys, ladder, visual gauge, cleaning cloth



### TIME

25-35 min

01  
02  
03  
04  
05  
06  
07  
08